



ESPOSTORI e BANCHI
SHOWCASES and COUNTERS



LINEA LUSO
LUXURY-LINE



BUFFET Gastronomia
Gastronomy BUFFET



VESTRINE: vini, bevande, gelati
DISPLAY: wines, drinks, ice cream



ARMADI refrigerati semi-professionali
Semi-professional refrigerated CABINETS



RISTORAZIONE
CATERING Equipment



MINIMARKET
Minimarket



COLIBRI

RESTYLING



ACCESSORIO / ACCESSORIE:
Mensole portapiatti snodabili
Tipping plate-holder shelves

Colore standard
Standard color



COD. 89

		°C	mm. (LxPxH)	h. MIN. 100 mm. h. MAX. 150 mm.	Watt	H ₂ O				Kg.	
Colibri		+4/+10	1423x750x1184	GN 2/1-1/1 2/3-1/2-1/3	600	AUT	230v/1/50Hz		R404a	95	-

Dati di collaudo • Test details • Détails d'essai • Prüfungsergebnisse • Datos de ensayo • MAX = (25°C - % U.R. 60)





ESPOSTORI e BANCHI
SHOWCASES and COUNTERS



LINEA LUSSO
LUXURY LINE



BUFFET Gastronomie
Gastronomy BUFFET



VETRINE: vini, bevande, gelati
DISPLAY: wines, drinks, ice cream



ARMAD: refrigerati semi-professionali
Semi-professional refrigerated
CABINETS



RISTORAZIONE
CATERING Equipment



MINIMARKET
Minimarket



COLIBRI

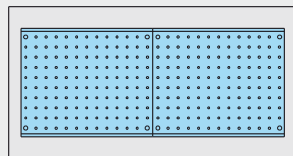
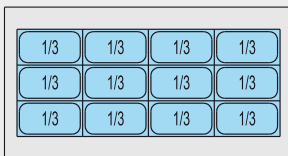
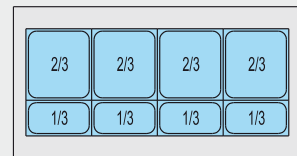
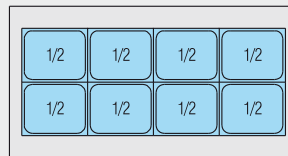
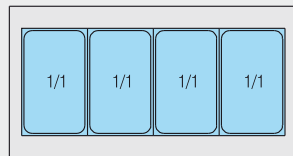
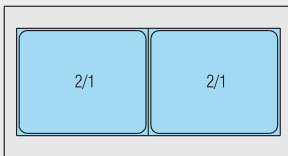
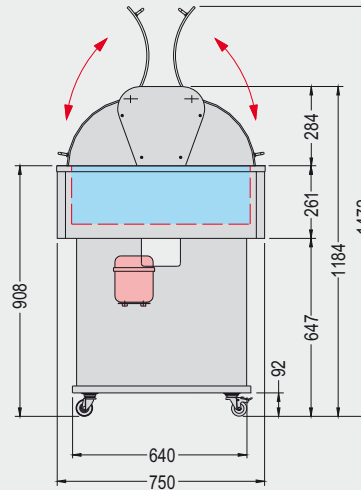
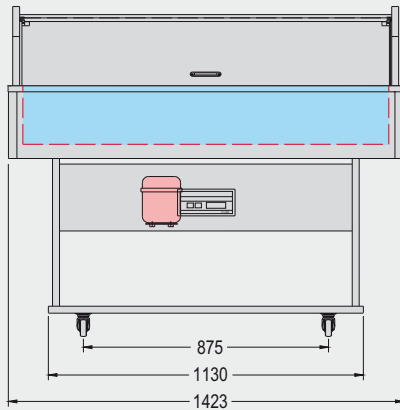

Le bacinelle GN sono fornite a richiesta / GN basins are available on request / Les bacs sont fournis sur demande / Die Schalen werden auf Wunsch geliefert / Las cubetera se entregan bajo pedido



* LxPxH: 1270x505x90 mm

* Vassoio unico per piatti pronti e pasticceria (fornito a richiesta) / Tray for ready-to-serve dishes or pastry (supplied on request) / Plateau pour plats cuisines ou patisserie (fourni sur demande) / Ein Einziges Tablett für Patisserie oder Fertige Speisen (Lieferbar auf Anfrage) / Bandeja para platos listos o para pastelerias para llevar (bajo demanda)

Apertura **MANUALE** delle cupole / **MANUAL** opening of the domes / Ouverture **MANUEL** des coupoles / **MANUELLES** Öffnung der Kuppeln / Apertura **MANUAL** de las cúpulas

